

65-78GHz GaAs MMIC Low-Noise Amplifier

Product Datasheet V3

Features

- Frequency Range: 65 to 78 GHz
- Drain Voltage 1V (VD1/2/3)
- 2.4dB Noise Figure Typical
- 23dB Small Signal Gain
- 50Ω matched RF ports
- Die size: 3.0mm x 1.0mm x 0.1mm

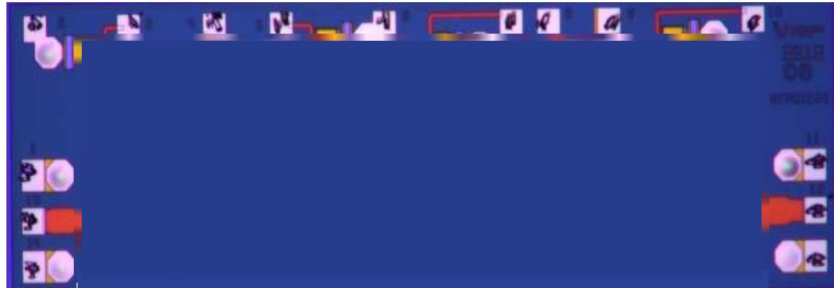

Description

The VRFA0122-BD is a 3-stage low noise amplifier MMIC which operates over the frequency range of 65GHz to 78GHz. The device demonstrates a typical noise figure of 2.4dB with small signal gain of 23dB across the frequency band. Each stage of the VRFA0122-BD is biased from a +1V DC supply. Total current drawn is 38mA. The RF ports are matched to 50Ω.

Applications

- Radar and Test & Instrumentation
- VSAT
- High Frequency Point to Point Radio

Electrical Specifications

$T=+25^{\circ}\text{C}$, $V_D = +1\text{V}$, $I_{DQ} = 38\text{mA}$, $V_g = -0.22\text{V Typ.}$

| Parameter | Specification | | | Unit |
|---------------------|---------------|------|------|------|
| | Min. | Typ. | Max. | |
| Frequency Bandwidth | 65 | | 78 | GHz |
| Small Signal Gain | 22 | 23 | 25.5 | dB |
| Noise Figure | 2.1 | 2.4 | 2.6 | dB |
| I/P Return Loss | -11 | -11 | -10 | dB |
| O/P return Loss | -6 | -6 | -5 | dB |

65-78GHz GaAs MMIC Low-Noise Amplifier

Product Datasheet V3

Measured Performance

$T=+25^{\circ}\text{C}$, $V_{DD}=+1\text{V}$, $I_{DQ}=38\text{mA}$ (Reference Plane: RF Bond Pads)

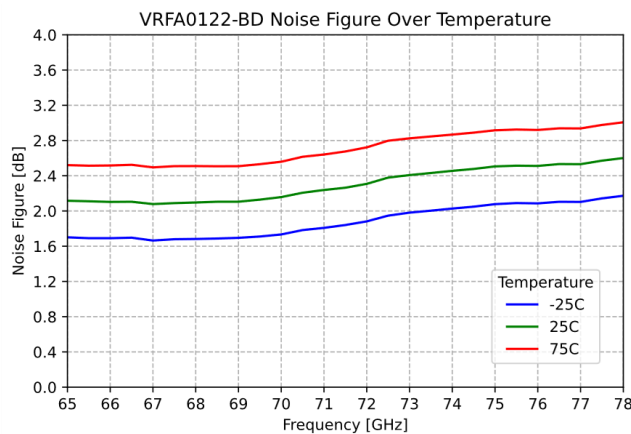
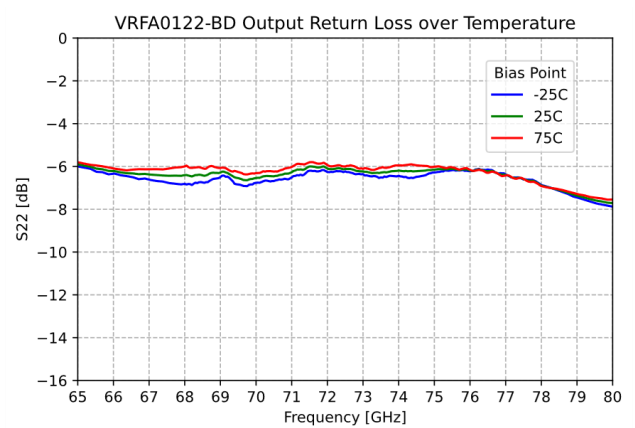
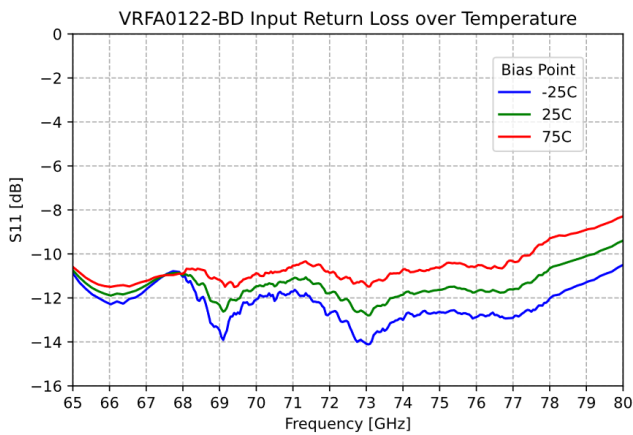
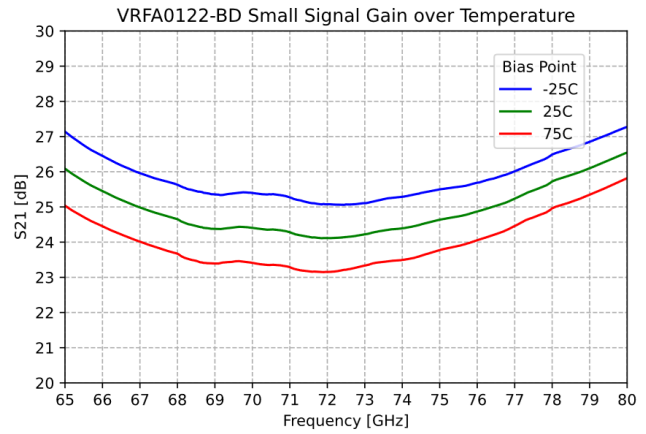
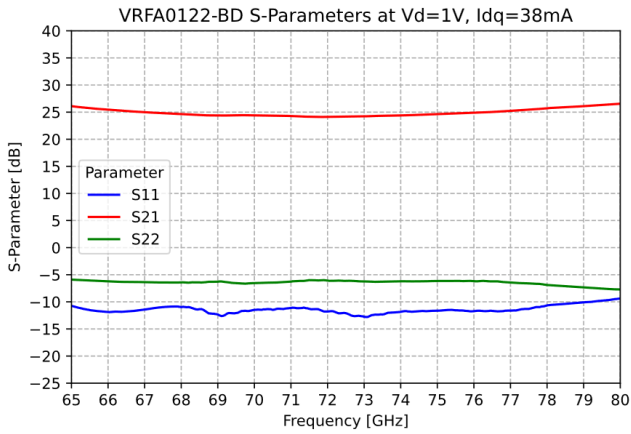

65-78GHz GaAs MMIC Low-Noise Amplifier

Product Datasheet V3

Recommended Absolute

Maximum Ratings ^{[1][2]}

| Parameter | Value |
|-----------------------|---------------|
| Drain Bias Voltage | +1.25V |
| Junction Temperature | 150°C |
| Operating Temperature | -40 to 85°C |
| Storage Temperature | -55 to 150 °C |

Pin Configuration

| Pin # | Description | Pin # | Description |
|-------|-------------|-------|-------------|
| 1 | RF Ground | 9 | Ground |
| 2 | Ground | 10 | Vd3 |
| 3 | Vg1 | 11 | RF Ground |
| 4 | Vd1 | 12 | RF Output |
| 5 | Vg2 | 13 | RF Ground |
| 6 | Ground | 14 | RF Ground |
| 7 | Vd2 | 15 | RF Input |
| 8 | Vg3 | N/A | N/A |

Recommended Operating Conditions

| Parameter | Value |
|---------------|--------|
| Drain Voltage | +1.00V |
| Drain Current | 38mA |

Decoupling Diagram

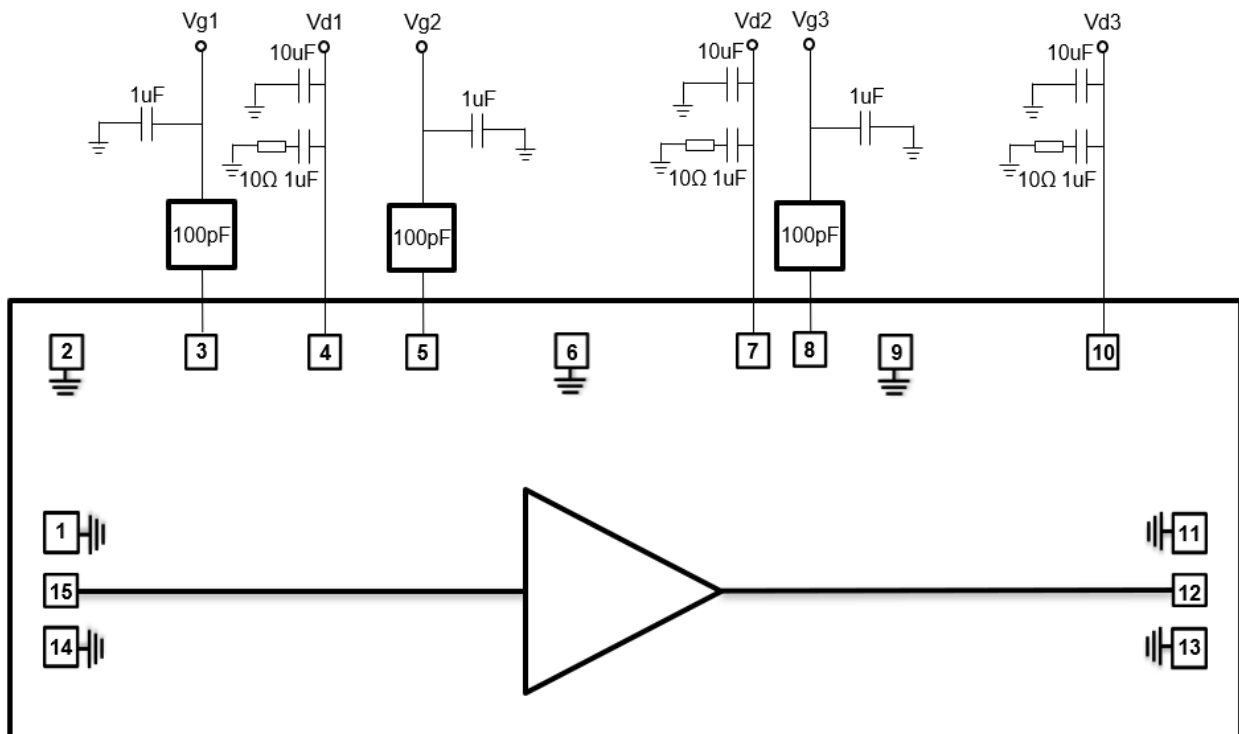

[1] Operation outside these conditions may cause permanent damage to the device.

[2] Combination of maximum rating conditions may reduce the values. Device performance at these ratings is not implied.

65-78GHz GaAs MMIC Low-Noise Amplifier

Product Datasheet V3

Assembly Diagram

All units are in um

| Pad # | Location ^[3] (x,y) | | Pad # | Location ^[3] (x,y) | |
|-------|-------------------------------|--------|-------|-------------------------------|-------|
| Pad # | X / um | Y / um | 8 | 1946.5 | 873.5 |
| 1 | 126.5 | 428 | 9 | 2158.5 | 873.5 |
| 2 | 138.3 | 873.5 | 10 | 2666.5 | 873.5 |
| 3 | 467.8 | 873.5 | 11 | 2878.5 | 428 |
| 4 | 873.5 | 873.5 | 12 | 2878.5 | 289 |
| 5 | 1005.5 | 873.5 | 13 | 2878.5 | 150 |
| 6 | 1368.5 | 873.5 | 14 | 126.5 | 150 |
| 7 | 1814.5 | 873.5 | 15 | 126.5 | 289 |

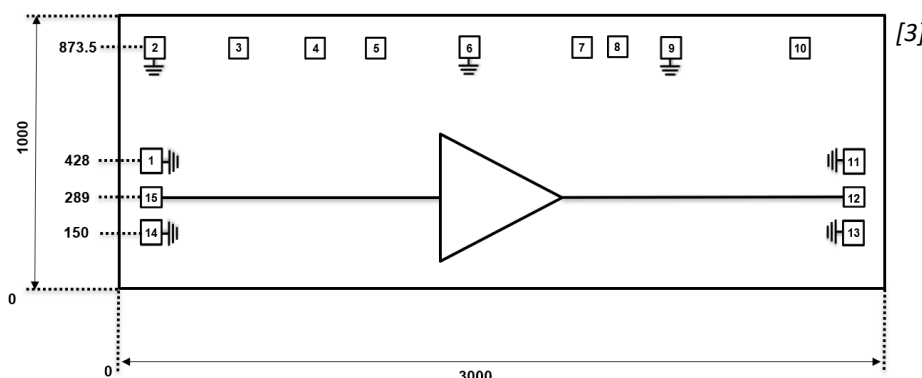

[3] From origin to centre of pad, diagram not to scale.

| Parameter | Value |
|-------------------------|-------------|
| Drain bond pad opening | 80um x 80um |
| RF bond pad opening | 80um x 80um |
| RF GND bond pad opening | 80um x 97um |
| Die size | 3mm x 1mm |
| Die thickness | 100um |

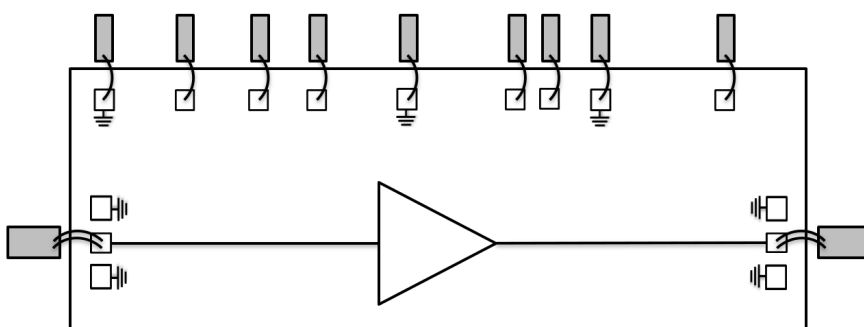

Order Information

| Part Number | Package |
|--------------|-----------------|
| VRFA00122-BD | Die in Gel Pack |

GaAs devices are ESD sensitive and precautions should be observed during storage, handling, assembly and testing.

